



# Pressure Seals, Inc.

Phone: (877)-PSI-SEAL Toll Free  
Thousands of Seals, O-Rings, and U-Cups  
World-Class Service since 1976!



## M8791/1

### Back-up Ring, Single Turn

**Requirements:**

1. Surfaces and Edges: Surfaces shall be smooth and free from irregularities. Edges shall be clean and sharp.
2. Scarf Cut: When measuring dimension "M" ±0.001 inches over a mandrel, the scarf cut shall not exceed dimension "G" and no overlap of the scarf ends is permitted beyond dimension "T".
3. Part Number: The part number consists of the letter "M", the basic number of this specification sheet, followed by a dash number taken from the Table.

Example: M8791/1-004  
Specification Sheet Number 1  
Dash Number 004

**Note:**

For Larger Packing Retainers (Back-up Rings) in this Series, Uncut Packing Retainers MS27595 are recommended.

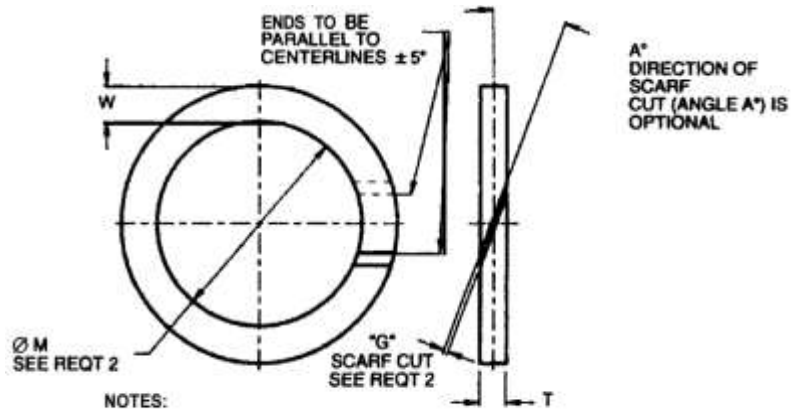

**NOTES:**

1. All dimensions are in inches
2. For use in packing grooves conforming to ML-G-5514 and MIL-P-5514C, D and E revisions

Dash No.	M Dia.	Tol.	T	W	G	
004	0.076					39-35
005	0.108					29-27
006	0.123					26-24
007	0.154					20-19
008	0.185					
009	0.217					
010	0.248					
011	0.310					
012	0.373					
013	0.438					
014	0.501					
015	0.563					
016	0.626	±0.001	0.052	0.054	0.005	22-19
017	0.688		0.048	0.052	0.000	
018	0.751					
019	0.813					
020	0.881					
021	0.943					
022	1.006					
023	1.068					
024	1.131					
025	1.193					
026	1.256					
027	1.318					
028	1.381					
110	0.373					
111	0.435					
112	0.498	±0.001	0.056	0.087	0.006	22-19
113	0.560		0.052	0.085	0.000	
114	0.623					

Dash No.	M Dia.	Tol.	T	W	G	
115	0.685					
116	0.748					
117	0.815					
118	0.878					
119	0.940					
120	1.003					
121	1.065					
122	1.128					
123	1.190					
124	1.253					
125	1.315					
126	1.380					
127	1.442					
128	1.505					
129	1.564	±0.001	0.056	0.087	0.006	22-19
130	1.627		0.052	0.085	0.000	
131	1.689					
132	1.752					
133	1.814					
134	1.877					
135	1.940					
136	2.002					
137	2.065					
138	2.127					
139	2.190					
210	0.748					
211	0.810					
212	0.873	±0.001	0.064	0.120	0.006	22-19
213	0.935		0.060	0.118	0.000	
214	0.998					

Pressure Seals Inc. 81 Commerce Way, South Windsor, CT 06074

Phone: (877)-PSI-SEAL Toll Free, In CT: (860) 282-9100, Fax: (860) 282-9001



# Pressure Seals, Inc.

Phone: (877)-PSI-SEAL Toll Free  
 Thousands of Seals, O-Rings, and U-Cups  
 World-Class Service since 1976!



## M8791/1 Continued

Back-up Ring, Single Turn

Dash No.	M Dia.	Tol.	T	W	G	
215	1.060					
216	1.123					
217	1.185					
218	1.248	±0.001	0.064	0.120	0.006	22-19
219	1.310		0.060	0.118	0.000	
220	1.373					
221	1.435					
222	1.498					
223	1.625					
224	1.750				0.007 0.000	
225	1.875					
226	2.000					
227	2.125					
228	2.250					
229	2.375					
230	2.500					
325	1.498					
326	1.623					
327	1.748					
328	1.873					
329	1.998					
330	2.123	±0.001	0.090	0.184	0.007	22-19
331	2.248		0.086	0.182	0.000	
332	2.373					
333	2.498					
334	2.623					
335	2.748					

Dash No.	M Dia.	Tol.	T	W	G	
336	2.873					
337	2.997					
338	3.122					
339	3.247					
340	3.372					
341	3.497					
342	3.747	±0.001	0.090	0.184	0.007	22-19
343	3.872		0.086	0.182	0.000	
344	3.872					
345	3.997					
346	4.122					
347	4.247					
348	4.372					
349	4.497					
425	4.497					
426	4.622					
427	4.747					
428	4.872					
429	4.997					
430	5.122	±0.001	0.122 0.118	0.237 0.235	0.008 0.000	22-19
431	5.247					
432	5.372					
433	5.497					
434	5.622					
435	5.747					
436	5.872					
437	5.997					

Pressure Seals Inc. 81 Commerce Way, South Windsor, CT 06074

Phone: (877)-PSI-SEAL Toll Free, In CT: (860) 282-9100, Fax: (860) 282-9001