



# Pressure Seals, Inc.

Phone: (877)-PSI-SEAL Toll Free  
 Thousands of Seals, O-Rings, and U-Cups  
 World-Class Service since 1976!



CODE IDENT. 07128

## TF 454

PISTON SEAL INSTALLATION  
 FOR MIL-P-5514  
 (C, D & E REVISIONS)  
 TWO BACK-UP GLAND

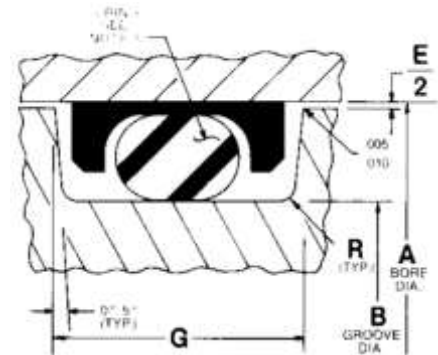

Dash No.	G Groove Width		R Groove Radius	E Diametral Clearance Max.
	+0.010	-0.000		
004-012	0.207		.005-.015	0.004
013-028	0.207		.005-.015	0.005
110-127	0.245		.005-.015	0.005
210-247	0.304		.010-.025	0.006
325-349	0.424		.020-.030	0.007
425-460	0.579		.020-.030	0.010

**Notes:**

- This part is supplied in virgin TFE. For other material callouts, refer to Technical Data section.
- Dash numbers correspond to AS568.
- O-ring supplied on request. Size is same as seal dash size.
- Parts supplied with sidewall notches.
- This part also supplied with Minigrooves®; add "M" after basic part no. for Minigroove configuration.
- Part Dash Numbers 008 through 012; 110 through 116; 210 through 222 and 325 through 349 conform to Boeing SCDBACR12BH.

**Ordering Instructions:**

Example: TF 454 M-214N  
 Basic P/N  
 For Minigroove only  
 Size Dash No.  
 For sidewall notches

**Ordering Instructions for Boeing Part Number BACR12BH**

(See Note 6):

Example: BACR12BH-214 AorB  
 Basic P/N  
 Size Dash No.  
 Material Code  
 A-BMS8-121 Typ. 1, GR.B, CL. 1  
 B-MIL-R-8791

Dash No.	A Dia.		B Dia.		Dash No.	A Dia.		B Dia.		Dash No.	A Dia.		B Dia.	
	+0.001	-0.000	+0.000	-0.001		+0.002	-0.000	+0.000	-0.002		+0.002	-0.000	+0.000	-0.002
004	0.190		0.076		214	1.241		0.998		340	3.744		3.372	
005	0.221		0.108		215	1.303		1.060		341	3.869		3.497	
006	0.235		0.123		216	1.366		1.123		342	3.994		3.622	
007	0.266		0.154		217	1.428		1.185		343	4.119		3.747	
008	0.297		0.185		218	1.491		1.248		344	4.244		3.872	
009	0.329		0.217		219	1.553		1.310		345	4.369		3.997	
010	0.360		0.248		220	1.616		1.373		346	4.494		4.122	
011	0.422		0.310		221	1.678		1.435		347	4.619		4.247	
012	0.485		0.373		222	1.741		1.498		348	4.744		4.372	
	+0.002		+0.000		223	1.868		1.625		349	4.869		4.497	
	-0.000		-0.002		224	1.993		1.750						
013	0.550		0.438		225	2.118		1.875			+0.003		+0.000	
014	0.613		0.501		226	2.243		2.000			-0.000		-0.003	
015	0.675		0.563		227	2.368		2.125		425	4.974		4.497	
016	0.738		0.626		228	2.493		2.250		426	5.099		4.622	
017	0.800		0.688		229	2.618		2.375		427	5.224		4.747	
018	0.863		0.751		230	2.743		2.500		428	5.349		4.872	
019	0.925		0.813		231	2.868		2.625		429	5.474		4.997	
020	0.993		0.881		232	2.993		2.750		430	5.599		5.122	
021	1.055		0.943		233	3.118		2.875		431	5.724		5.247	
022	1.118		1.006		234	3.243		3.000		432	5.849		5.372	
023	1.180		1.068		235	3.368		3.125		433	5.974		5.497	
024	1.243		1.131		236	3.493		3.250		434	6.099		5.622	
025	1.305		1.193		237	3.618		3.375		435	6.224		5.747	
026	1.368		1.256		238	3.743		3.500		436	6.349		5.872	
027	1.430		1.318		239	3.868		3.625		437	6.474		5.997	
028	1.493		1.381		240	3.993		3.750		438	6.724		6.247	
110	0.551		0.373		241	4.118		3.875		439	6.974		6.497	
111	0.613		0.435		242	4.243		4.000		440	7.224		6.747	
112	0.676		0.498		243	4.368		4.125		441	7.474		6.997	
113	0.738		0.560		244	4.493		4.250		442	7.724		7.247	
114	0.801		0.623		245	4.618		4.375		443	7.974		7.497	
115	0.863		0.685		246	4.743		4.500		444	8.224		7.747	
116	0.926		0.748		247	4.868		4.625		445	8.474		7.997	
117	0.993		0.815		325	1.870		1.498		446	8.974		8.497	
118	1.056		0.878		326	1.995		1.623		447	9.474		8.997	
119	1.118		0.940		327	2.120		1.748		448	9.974		9.497	
120	1.181		1.003		328	2.245		1.873		449	10.474		9.997	
121	1.243		1.065		329	2.370		1.998		450	10.974		10.497	
122	1.306		1.128		330	2.495		2.123		451	11.474		10.997	
123	1.368		1.190		331	2.620		2.248		452	11.974		11.497	
124	1.431		1.253		332	2.745		2.373		453	12.474		11.997	
125	1.493		1.315		333	2.870		2.498		454	12.974		12.497	
126	1.558		1.380		334	2.995		2.623		455	13.474		12.997	
127	1.620		1.442		335	3.120		2.748		456	13.974		13.497	
210	0.991		0.748		336	3.245		2.873		457	14.474		13.997	
211	1.053		0.810		337	3.369		2.997		458	14.974		14.497	
212	1.116		0.873		338	3.494		3.122		459	15.474		14.997	
213	1.178		0.935		339	3.619		3.247		460	15.974		15.497	

Pressure Seals Inc. 81 Commerce Way, South Windsor, CT 06074

Phone: (877)-PSI-SEAL Toll Free, In CT: (860) 282-9100, Fax: (860) 282-9001